



For Immediate Release

Press Contact

Geraldine Fairbairn

Phone: +61 2 9635 4881

pr@3ivx.com

3ivx MPEG-4 5.0 released at CES

Las Vegas, Nevada, January 8, 2007 - 3ivx Technologies Pty. Ltd., the MPEG-4 Video & Audio specialist, announces the immediate availability of version 5.0 of 3ivx MPEG-4 software for Windows, Mac OS X & Linux. This release is the culmination of 7 years research and development.

3ivx's compression technology enables the transmission and storage of video which would otherwise be too large to store or transmit. 3ivx MPEG-4 5.0 consists of separate MPEG-4 Audio, MPEG-4 Video and MP4 File Format components for authoring and playback of MPEG-4 media.

Portable Media

An ever-increasing range of Portable Media Players including Mobile Phones and Video iPods support MPEG-4 playback. 3ivx MPEG-4's unrivaled video quality and standards compliance is ideal for portable media and is why 3ivx is already in wide use by the video podcasting community.

IPTV and DRM

IPTV is gaining in popularity as an alternative to analog television. The major challenge with digital delivery is the protection of content against illegal copying. To combat this, support for Digital Rights Management systems has been added to 3ivx MPEG-4 5.0. 3ivx is now the only MPEG-4 solution for delivering secure content to both QuickTime and Windows Media Player.

HDTV

60 million households will have at least one wide screen, High-Definition TV display in their home by the end of 2007, according to In-Stat predictions. The ability to produce broadcast quality compressed video in realtime makes 3ivx MPEG-4 5.0 uniquely suited for HDTV production environments. 3ivx produces high quality HD MPEG-4 Video with 5.1 Surround Sound MPEG-4 AAC Audio in less than half the bandwidth of comparable MPEG-2 Video streams.

Bundling and Integration

By bundling 3ivx MPEG-4 5.0, a developer gains access to simple, reliable and effective MPEG-4 reading, writing and authoring support. Licensing 3ivx is a cost effective and straight forward solution for adding MP4 support to an existing product. 3ivx can be integrated by developers using either DirectShow, QuickTime or Video For Windows APIs, or as native libraries.

3ivx Technologies will be exhibiting at the 2007 International CES in Las Vegas at booth #54,019 in the Las Vegas Hilton, where 3ivx MPEG-4 5.0 will be demonstrated.

3ivx Technologies Pty. Ltd., a leading provider of MPEG-4 software, is a dynamic Australian company that has a creative team of software and hardware developers. Headquartered in Sydney, Australia, 3ivx Technologies distributes its products primarily in North America, Asia and Europe.

More information is available at the 3ivx website
<http://www.3ivx.com>

###



3ivx MPEG-4 5.0

Information Pack

What is 3ivx?

3ivx MPEG-4 is a mature industry standard video compression system which enables the transmission and storage of video, which would otherwise be too large to store or transmit. 3ivx MPEG-4 5.0 consists of separate MPEG-4 Audio, MPEG-4 Video and MP4 File Format components for authoring and playback of MPEG-4 media.

This information Pack covers the various components that make up the 3ivx MPEG-4 5.0 software suite.

Contents

The Portable Media Revolution	2
IPTV and DRM	4
High Definition MPEG-4	5
Bundling, Integration & Licensing	6
Integration	6
Bundling	6
Licensing	7
3ivx MPEG-4 Video	8
Performance	8
Image Quality	8
Portability	8
Interoperability	9
3ivx MPEG-4 Audio	9
3ivx MPEG-4 Media	9

The Portable Media Revolution

The Portable Media Revolution is a growing trend where video can be consumed anywhere at anytime, in a hotel room, on public transport or in the garden. End-users don't want to be limited to watching television at a fixed time and at a fixed location.



The Portable Media Revolution was kick-started virtually overnight when the Video iPod and Sony PlayStation Portable (PSP) were both released with MPEG-4 playback capabilities.

As of 2007, the majority of Portable Media Players currently on the market are MPEG-4 compatible.



Portable Media Players are devices that have the ability to play both audio and video content. Examples of PMPs include mobile phones with video playback, PDAs, UMPCs and MP4 Players.

Mobile Phones are often used for viewing small video clips. A number of commercial services have launched that make news and sport items available via mobile phones to individuals who would like to stay up-to-date on the latest developments. Devices with larger screens are often used for watching TV episodes and full movies while on the go.

The recording of video on portable media devices is another facet of the Portable Media Revolution. Mobile phones with built-in cameras for example support the recording of short clips for showing or forwarding to friends. The same is true for digital still cameras as well as for memory card and DV camcorders.

3ivx and the Portable Media Revolution

3ivx's MPEG-4 encode and playback capabilities make the software a perfect complement to portable media devices. 3ivx MPEG-4 5.0 bridges the gap between the device and the user's Personal Computer by adding support for MPEG-4 encoding and playback to Windows. This significantly increases the value and effective usefulness of the portable device. This is why consumer electronics manufacturers such as Samsung bundle the 3ivx software with their MPEG-4 capable products.



Playback

When users record video clips with their digital camera or other portable device, they often wish to play or edit these clips on their PC. Windows does not come with software to play MPEG-4 or 3GPP videos. With 3ivx installed it is possible to play these video clips in Windows Media Player or edit them in Adobe Premiere, Windows Movie Maker or other applications.

Encoding



3ivx MPEG-4 is an efficient video encoder which delivers great looking video even when encoding for mobile devices. Furthermore 3ivx ensures that encoded video is MPEG-4 compliant and plays back on MPEG-4 compatible devices. The 3ivx software also supports 3GPP which is the standard format for mobile video. Many video podcasters recognize these advantages and use 3ivx MPEG-4 as their distribution format.

The increasing adoption of 3ivx MPEG-4 5.0 in the Portable Media Arena will foster device interoperability and greater user satisfaction.

IPTV and DRM

IPTV is gaining in popularity as an alternative to analog television. A major challenge with digital delivery is the protection of content against illegal copying. Although there are Digital Rights Management systems available for IPTV, none are cross-platform and standards based.

In cooperation with Mutable Media, 3ivx has added support for playback of protected MP4 files to the 3ivx software components. 3ivx MPEG-4's unique cross-platform

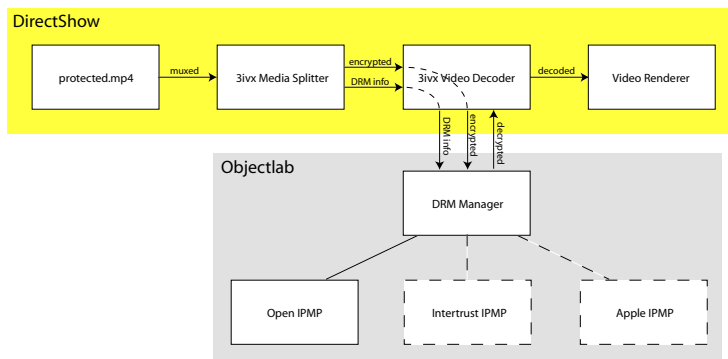

3ivx DRM Manager Architecture

availability enables the same protected content to be delivered to both QuickTime and Windows Media Player. DRM support has been added in such a way that it is potentially possible for any DRM system to plug into the 3ivx MPEG-4 software. When decoding, the 3ivx components interface with the DRM Manager to handle decoding and decryption requests. The DRM Manager in turn decides which DRM system is to be used and will interact with the relevant system. The diagram to the left outlines the workings of the system.

A typical DRM architecture consists of a Media Server, a Rights Server and a Client. The Media Server can either serve pre-encrypted media files or secure live video as you go. To encrypt files a utility is used for converting unprotected MP4 files into protected MP4 files. The Rights Server makes keys available and also manages the rights of the user for accessing the content. The Client consists of a DRM Manager for communicating with the Rights Server and decrypting the content through the DRM system and Audio and Video components for playing the content when the rights have been cleared.

The quality of video available from an IPTV system is wholly dependent on the video encoder employed to compress the source video before encryption. 3ivx MPEG-4 5.0 delivers industry leading compression efficiency with optimal image quality along with encoder modes specifically designed for On-Demand Video and Live Streaming applications.

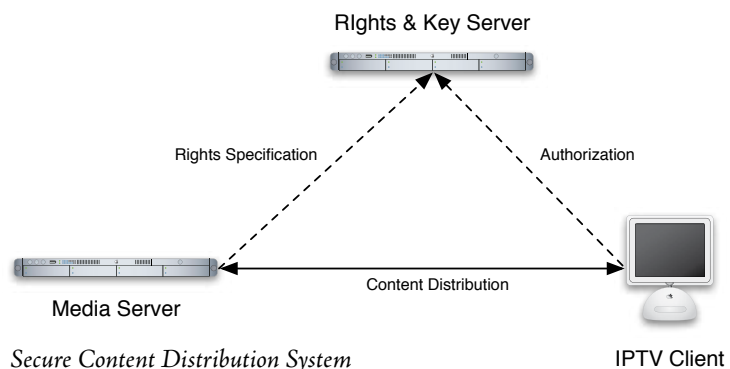

Secure Content Distribution System

3ivx is the perfect source encoder for IPTV, and with 3ivx MPEG-4 5.0's enhanced DRM capabilities, is now the only choice for delivering content in a standards based, cross-platform IPTV system.

High Definition MPEG-4

60 million households will have at least one wide screen, High-Definition TV display in their home by the end of 2007, according to In-Stat predictions. The ability to compress broadcast quality High Definition video in realtime makes 3ivx MPEG-4 5.0 uniquely suited for HDTV production environments. 3ivx produces high quality HD MPEG-4 Video with 5.1 Surround Sound MPEG-4 AAC Audio in two to four times less bandwidth than comparable MPEG-2 Video streams.

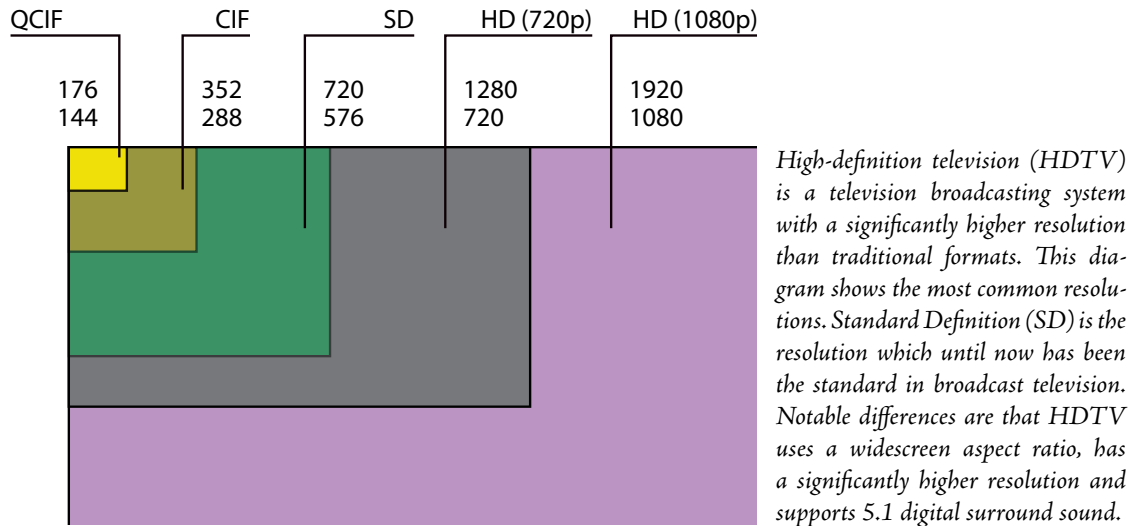

Video distribution channels are typically constrained by the available bandwidth, by decreasing the bandwidth required to transmit video at a given resolution, 3ivx allows either more channels to be transmitted in the same bandwidth, or the video can be transmitted in a higher resolution. By utilizing 3ivx an SD channel can be upgraded to HD without increasing the allocated bandwidth, or multiple HD channels can be transmitted instead of just one.

HD 1080p video has 6 times the spatial resolution of Standard Definition video, which means it also has approximately 6 times the coding complexity. Realtime encoding is important when dealing with video in many situations, but without a fast implementation realtime encoding will not be possible on commodity PC hardware. 3ivx MPEG-4 5.0 features extensive algorithmic optimizations and hand-coded vector assembly functions, making 3ivx one of the fastest MPEG-4 implementations available, all without sacrificing final output quality.

With the rapid consumer uptake of HD recording equipment the need for better video compression in the consumer realm has never been more important. Most current HD consumer and prosumer video cameras use the HDV video format, which is essentially MPEG-2 on a MiniDV tape. 3ivx can be used to compress HD video just as effectively in the consumer space as it can in the broadcast space. Using 3ivx consumers will be able to store more and do more with their video content.

3ivx MPEG-4 5.0's support for High Definition video and Surround Sound audio with industry leading compression efficiency makes 3ivx an ideal format for HD encoding. Combined with speedy realtime performance there is every reason to make use of 3ivx for HD video storage and transmission.

Bundling, Integration & Licensing

By bundling 3ivx MPEG-4 5.0 a developer gains access to simple, reliable and effective MPEG-4 reading, writing and authoring support. Licensing 3ivx is a cost effective and straight forward solution for adding MP4 support to an existing product. 3ivx can be integrated by developers using either DirectShow, QuickTime or Video For Windows APIs, or as native libraries.

Integration

The 3ivx MPEG-4 5.0 software suite is composed of a number of front-end components and core libraries. The front-end components make use of the core libraries to implement modules which can be used by the common media architectures on the chosen platform.

Developers can target 3ivx via the DirectShow, QuickTime or Video For Windows APIs, or they can directly link to the 3ivx core libraries. The core libraries are Lib3ivx, libAAC2 and libTMux, which respectively handle Video, Audio and Media tasks.

The 3ivx SDK provides the headers required to link to and configure the components. Extensive documentation and examples in C++ and C# are also supplied.

Generally on the Windows platform we would recommend the DirectShow API as it is ubiquitous, very flexible and well understood. On Mac OS X you must use QuickTime if you wish to use a system media architecture. As there is no predominant media architecture on most other unix and linux-like systems, we recommend linking directly against the 3ivx Core Libraries on these platforms.

Bundling

In order to balance feature and capability requirements, 3ivx MPEG-4 5.0 is available in multiple versions for bundling. The most popular version is the Lite version which contains both audio and video components but is limited to stereo audio (as opposed to surround sound) and only decodes LC-AAC Audio.

	Video Decoder	Video Encoder	Media Splitter	Audio Muxer	Audio Decoder	HE-AAC Encoder	Max. # of AAC Channels
3ivx MPEG-4 Decoder NoAudio	✓	✓					
3ivx MPEG-4 Decoder Lite	✓	✓		✓			2
3ivx MPEG-4 Decoder Standard	✓	✓		✓		✓	2
3ivx MPEG-4 Decoder Multi-Channel	✓	✓		✓			5.1
3ivx MPEG-4 Decoder Deluxe	✓	✓		✓		✓	5.1
3ivx MPEG-4 NoAudio	✓	✓	✓	✓			
3ivx MPEG-4 Lite	✓	✓	✓	✓	✓		2
3ivx MPEG-4 Standard	✓	✓	✓	✓	✓	✓	2
3ivx MPEG-4 Multi-Channel	✓	✓	✓	✓	✓		5.1
3ivx MPEG-4 Deluxe	✓	✓	✓	✓	✓	✓	5.1

Licensing

The 3ivx software is available for licensing on a per copy basis, in bulk or as an ongoing license with quarterly reporting and remittance cycles.

The per copy license fee is calculated based on the amount of units and the version you would like to license. To simplify customers reporting requirements the MPEG and associated patent license fees can be integrated into the overall 3ivx license fee.

Additionally 3ivx can perform tailoring and custom development subject to availability of engineering resources. The development cost varies depending on the engineering effort involved and the core applicability.

3ivx MPEG-4 5.0 is the simplest, most cost-effective way for a developer to rapidly add high-quality standards compliant MPEG-4 support to an application. 3ivx's straight-forward bundling options and proven approach to licensing ensure that your project will be a success.

3ivx MPEG-4 Video

3ivx MPEG-4 Video is a powerful compression solution that caters for high end applications such as High Definition 1080p video with Surround Sound as well as for preparing video clips for viewing on mobile players including the Video iPod, Sony PSP and Mobile Phones.

The 3ivx software generates video that is fully compliant with the MPEG-4 Simple or Advanced Simple Profiles. 3ivx MPEG-4 5.0 has been designed for performance (speed), image quality, interoperability and portability.

The video encoder components cater for multiple different scenarios some examples are Real-time Encoding, Video-On-Demand, Archiving, Streaming and Multimedia Authoring. While the video decoder components can be used for video playback in Windows Media Player, Internet Explorer and any application that uses a system wide architecture.

Performance

3ivx MPEG-4 5.0 is very fast, if not the fastest MPEG-4 video codec available.

The 3ivx software heavily benefits from fast memory buses, fast processors and MMX, SSE, SSE2 and AltiVec. The codec uses only a minimal amount of RAM. For example, only 143 kilobytes of RAM is required for QCIF sized (176x144) video.

The 3ivx Video Decoder utilizes high quality post-processing filters that are controlled by the Speed Governor. The Speed Governor dynamically enables and disables post-processing filters depending on the amount of CPU time that is available.

Image Quality

Encoder Quality

The goal of the encoding process is to produce results which most closely resemble the original footage. High quality algorithms are used to preserve as much detail, in as little space as possible.

Decoder Quality

The decoder quality is a combination of the advanced core decoding routines and adaptive post processing filters. These routines have been carefully designed to enhance the perceived quality of the image.

Portability

The 3ivx software has been ported and optimized for a variety of platforms. This includes both desktop platforms (Windows and Mac OS X) and architectures (IA32, PPC) as well as embedded devices (XScale/ARM).

The video components are available for DirectShow, Video for Windows, QuickTime and as stand-alone libraries.

Interoperability

The 3ivx MPEG-4 Decoder, is compatible with the MPEG-4 Simple and Advanced Simple Profiles. Footage encoded with 3ivx MPEG-4, DivX 3, 4, 5 and 6, Apple MPEG-4, Philips MPEG-4, XviD, Sorenson MPEG-4 and MPEGSolutions MPEG-4 and variants have successfully been tested. 3ivx also supports multiple consecutive B-frames (B-VOPs), 3 Warp-Point Global Motion Compensation (GMC), Interlaced Video, MPEG Quantization, Custom Quantization and Quarter Pixel (QPel) motion compensation.

3ivx MPEG-4 Audio

Advanced Audio Coding (AAC) is significantly more efficient than other Audio formats such as MP3 and Dolby Digital. MPEG-4 Multi-Channel AAC provides high fidelity surround sound which is an ideal complement to High Definition video.

The 3ivx MPEG-4 Audio Encoder generates bitstreams that are compatible with QuickTime 6 and 7 (Apple MPEG-4), iPods, Philips Platform4 Player (Philips MPEG-4) and other players that are compliant with the Low Complexity AAC (LC-AAC) Object Type.

The 3ivx Audio Decoder also supports HE-AAC for improved audio quality at lower bitrates.

3ivx MPEG-4 Media

The 3ivx Media components are essential for playing MP4, M4A, 3GP and MOV files inside Windows Media Player and other DirectShow compatible applications. The components are also useful in QuickTime for opening MOV and MP4 files as the standard QuickTime installation does not support some MPEG-4 features including Advanced Simple Profile and High-Efficiency AAC. Some MPEG-4 features exclusive to 3ivx are MPEG-4 aspect ratios, chapter lists and metadata.

The Media components recognize protected MP4 files and interface with the DRM Manager to handle decoding and decryption requests. Only after the rights for the user are cleared, is the video able to be viewed. The DRM Manager is implemented in a platform agnostic way that potentially allows any DRM or content management system to be adapted to function with the 3ivx components. The DRM/IPMP system makes use of the following standards ISMACryp, IPMP-X, OMA/ODRL, MPEG-REL, DOI, AES and Blowfish.

The 3ivx Media Muxer combines MPEG-4 Audio and Video streams into an MP4 or MOV file. It supports Advanced Features such as Multiple Audio tracks, Chapter Lists, Metadata, Variable Frame Rate Video, Positive and Negative Track Offsets, Automatic Audio Video Interleaving, Movie Fragments, AMR Tracks, System Tracks, VOBSUB Tracks, ESDS Extraction, ODSM Extraction, PAR Rewriting, Redundant VOSH Removal, Truncated VOSH Repair, Frame Re-Keying, NVop Compression, Compressed Headers and Progressive Download.

In combination with the 3ivx Media Splitter, the Muxer can repair broken MP4 streams generated by non-compliant MP4 File Writers or AVI codecs. The Media Muxer comes as a DirectShow Filter that can be used in GraphEdit or integrated with any DirectShow compatible application.